



ARV 5000
THINKY MIXER

POLY DISPENSING SYSTEMS
SYSTEMES DE DOSAGE INDUSTRIEL

Integrated Features

- Mixing
- Kneading
- Dispersion
- Deaeration at once
- From research to production, large capacity up to kg

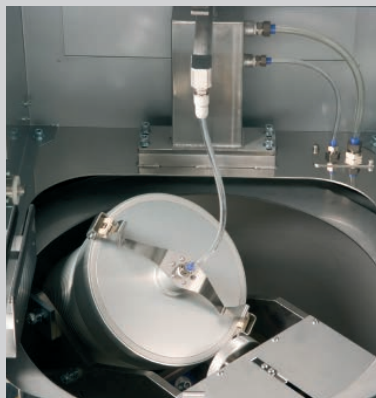

- Container can be loaded easily with wide opening



Thinky ARV 5000

- THINKY non-contact centrifugal mixing technology made it possible to mix, disperse and deaerate at once in a sealed container. All types of engineered materials in high and low density can be processed in minutes regardless the viscosity.
- Production on demand saves your time and money today.
- With the use of adapter and container, small quantity of sample can be processed. Share the same unit from research to production
- Equip various features for materials or process control with easy operation

Specification

Planetary Centrifugal Mixer Thinky Mixer ARV-5000	
Model	ARV-5000
Product name	Thinky Vacuum MIXER
Method	Vacuum centrifugal mixing technology
Program Memory	10 slots, each slot can control 10 steps continuously
Process Cycle Time	1 second to 30 minutes (per slot)
Revolution speed	200-800rpm
Rotation speed	150-160 rpm Follow 3/4 of Resolution Speed
Maximum mixing capacity	3 liters
Maximum mixing mass	4,7 kg (NET)
Upper limit using a 4 liters container	3 liters, 5kg (GROSS) 3 liters 4.7 kg (NET)
Vacuum Chamber	Cup holder style
Vacuum Range	90kPa-0.67kPa
Pump Speed	Within 60 seconds (atmosphere pressure to 0.67kPa)
Air break Time	Within 30 seconds (0.67kPa to atmosphere pressure)
Trap	Optional (externally connected joint)
Remote Operation	Optional
Safety Functions	Coversensor, Vibration sensor, Rotation sensor. Emergency Stop Button
Operating Environment	10-35 C° 35-85% RH (no condensation)
Power Supply	3 phase . AC200V \pm 10 %, 50/60 Hz Power consumption Standby : Approx 37VA Operatinf : Max 4,500VA
Dimensions	H1,600 x W1,000 x D865 (mm) *handles excluded
Machine Mass	Approx 500kg

ARV-5000

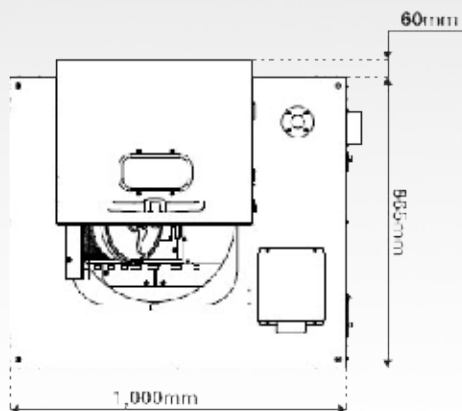

Control Panel

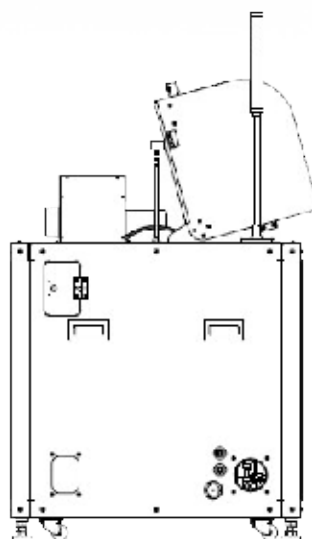
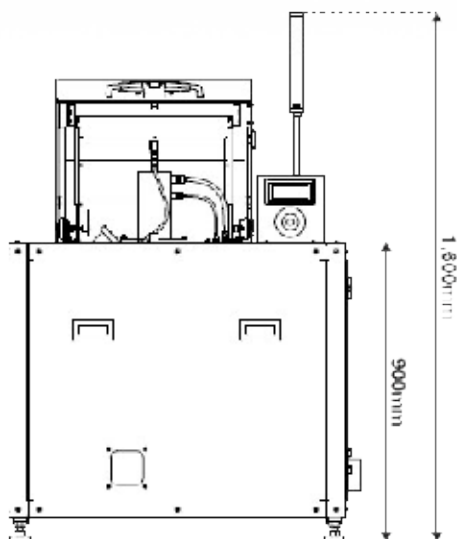

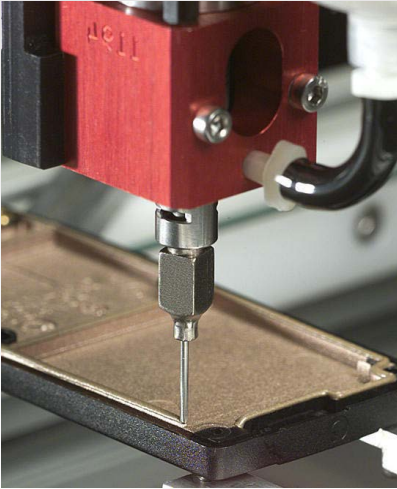

PDS S.A.S is a french company that commercializes a wide range of dosage equipments, proven and effective.

Distributed in over 20 countries around the world, these equipments provide tailored solutions to many users in order to improve technically their manufacturing and reduce their productions costs.

Our collaborators and sales engineers all have a strong technical competences. They are able to answer your questions and offer you, after analysis, the right solution for your particular need

FRANCE - SWITZERLAND
NORTH AFRICA

Poly Dispensing Systems
122, Chemin de la Cavée
78630 Orgeval

FRANCE

☎ + 33 (0)1 39 62 40 92

📠 + 33 (0)1 39 62 40 94

www.polydispensing.com

BELGIUM- HOLLANDE
LUXEMBOURG

Gentec Benelux
Rue de L'Industrie, 12
B-1400 Nivelles

BELGIUM

☎ +32 2 351 1800

📠 +32 2 351 1962

www.gentec-benelux.com

- NON CONTRACTUAL DOCUMENT -

POLY DISPENSING SYSTEMS

S Y S T E M E S D E D O S A G E I N D U S T R I E L