



GRACO

PR70

DISPENSING SYSTEMS

Two-component dispenser

DISPENSING SYSTEM PR70

BENEFITS

- Fixed or variable ratio
- Dispensing accuracy of 1%
- Accuracy ratio 1%
- Perfectly volumetric
- Different pump sizes and ratios
- Two-component system at affordable price
- Wide range of options available (heating - agitation etc.)
- All stainless steel system for a long term use
- Requires no maintenance
- Optimisation of tightness
- Adjustable power
- Reinforcement of steel parts in Chromex™

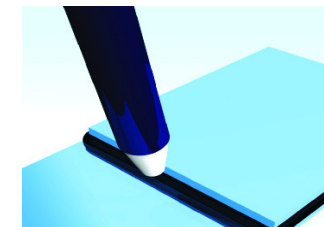
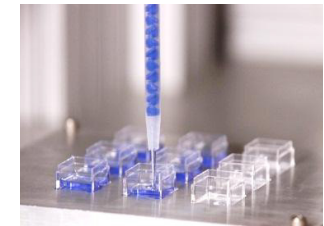
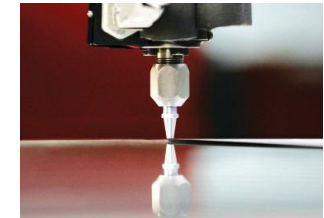

PRESENTATION

Major actor in the field of fluid transfer systems, Graco™ focused since many years on the technical excellence of his products.

Main distributor of the brand in the Benelux, Gentec offers systems with fixed and variable ratios of all PR70 range, dispense systems recognized for their quality with a unanimous success throughout all users. The complete serie of dispense systems PR70, dispenses, mixes and distributes accurately two components material, of a high-low viscosity, for the flows, gaskets, sealing, pottings, coatings and filling of the syringe.

So all the features you want are grouped into a single, compact and modular machine.

INDUSTRIES

- Electronics
- Composites
- Aeronautics
- Automotive components
- Equipment assembly
- Consumer electronics
- Sporting goods
- Appliances
- Medical

DISPENSING SYSTEM PR70

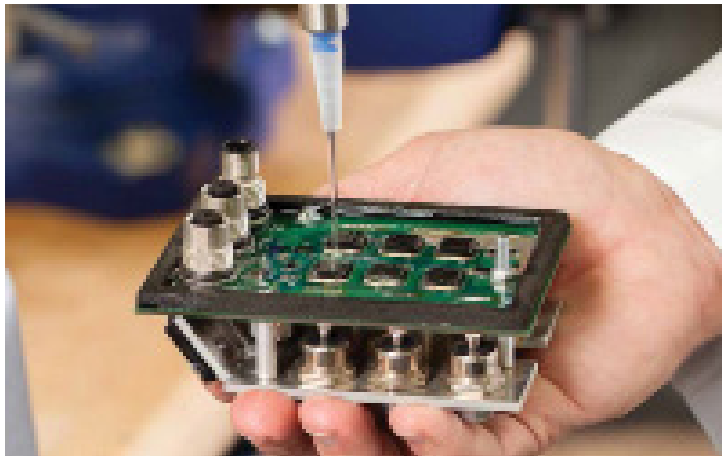

PR70 E (LCM)



PR70 (DM)

PR70 (ADM)



PR70 V (ADM)

System	System configuration	No	Yes	Yes	Yes
Ratio	Fixed ratio	1:1 to 12:1	1:1 to 12:1	1:1 to 12:1	NA
	Variable ratio	NA	NA	NA	1:1 to 24:1
Doses	Number of doses	1	5	50	50
	Doses based upon percentage of the piston stroke	Yes	No	No	No
	In weight doses	No	Yes	Yes	Yes
	Dispense > to the piston stroke	No	Yes	Yes	Yes
Supervision	Sequencing of dispense	No	In option	Yes	Yes
	Pressure control	No	In option	In option	In option
	Control ratio	No	In option	In option	In option
Data Control	Local control module (lcm)	Yes	No	No	No
	Display module (dm)	No	Yes	No	No
	Advanced display module (adm)	No	In option	Yes	Yes
	Gel timer	No	Yes	Yes	Yes
	Plc compatibility	No	Yes	Yes	Yes
	Usb download	No	In option	Yes	Yes

DISPENSING SYSTEM : PR70

MD2 Valve

High-pressure accuracy with multiple seat styles and adjustable snuffback for clean, precise dispensing

Intuitive User Interface

Digital shot size entry, machine monitoring and feedback for total control

Compact Benchtop Unit

Stable, strong machine base for secure installation. Small footprint saves valuable space

Long-Life Design

Optimized pump support, seal design, and Chromex rods provide twice the life of other systems



Multiple Feed Systems

A variety of feed package options are available :

- Polyethylene tanks
- Stainless steel tanks
- Off-board tanks for high-volume applications and reduced material refills
- Accumulators for high-viscosity materials

Fluid Control Module

Offers a simplified wiring system and board-level diagnostics

Modular approach is easier to operate, easier to maintain

Proven Ratio Accuracy

Multiple tube sizes to pinpoint specific target ratios and deliver ratio accuracy to $\pm 1\%$

Vacuum

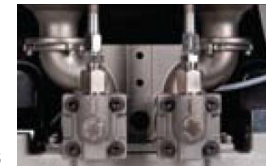

A standard basic machine with standard optional elements

PERFORMANCES PR70 ET PR70V

■ Rugged, reliable and durable

- Long-lasting wear parts mean lower cost of ownership
- Cast pump bodies for improved seal alignment
- Chromex™ shafts and Severe Duty™ cylinders combined with stainless steel fittings provide long pump life with no corrosion
- Shaft seals designed for extended life and easy replacement
- Preventive maintenance counter to plan system rebuilds around your production schedule
- Linear thrust bearings eliminate side loading to maximize seal life and performance

■ Handles most two-component materials

- Stainless steel design reduces the chance of a material incompatibility
- Positive displacement pumps deliver ratio accuracy to $\pm 1\%$
- Linear transducer monitors piston velocity to provide ratio assurance, and reduce scrap and re-work
- Shot size ranges from 2 to 70 cc's
- Ratio range from 1:1 to 24:1 with variable drive

DISPENSE SYSTEMS : PR70 V

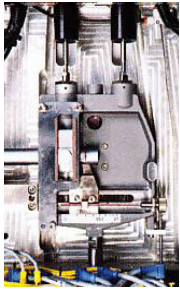

Variable ratio system

Changes the machine with different ratios. Supports all formulations



Optional accumulator

Allows you to manipulate high viscosity products

Advanced Display Module

Advanced Control screen for extended functions, including:

- Recirculation
- Programmable distribution, including independent sequences and up to 50 doses
- Cycle counters
- Keypad for easy data entry

Option dispensing valve

Choose between a fixed installation or a manually operated handle for better adaptation to your application

PERFORMANCES PR70 ET PR70V

■ Reliability and durability to maximize system performance

- Body molded pumps for better alignment of seals.
- The piston rods Chromex and Severe Duty cylinders piston associated with stainless steel fittings ensure a long service life of the pump without corrosion.
- Seals piston rods designed for extended life and easy replacement.
- Preventive maintenance counter to advise

maintenance of the unit based on the production schedule.

- Linear thrust bearings which eliminate side loads to maximize the lifetime and the performance of seals.

REMARKS

.....

.....

.....

.....

.....

.....

.....

.....

.....

.....

DISPENSING SYSTEM : PR70 E

- Multiple Feed Systems**
 - Polyethylene tanks
 - Stainless steel tanks
 - Off-board tanks for high-volume applications and reduced material refills
- Compact Benchtop Unit**
 - Stable, strong machine base for secure installation
 - Small footprint saves valuable space
- Long-Life Design**
 - Optimized pump support, seal design, and Chromex rods provide twice the life of existing systems



- MD2 Valve**
 - High-pressure accuracy with multiple seat styles and adjustable snuffback for clean, precise dispensing
- Local Control Module (LCM)**
 - Digital shot size entry
- Proven Ratio Accuracy**
 - Multiple tube sizes to pinpoint specific target ratios and deliver ratio accuracy to $\pm 1\%$

PERFORMANCES

■ The entry system

The PR70 E is the ideal model for anyone who is looking for a simple and intuitive dispense system, but providing reliable and accurate performance at a much lower cost than the PR70 or PR70 V.

Indeed, all the major functions you need are in this compact and modular design. The PR70E, mixes and dispenses the precise shot from low to medium viscosity for molding, sealing, coating and filling syringe.

REMARKS

■ Included :

- Fixed ratio basis
- Pipe 0.8 m long
- PE tank 8L
- MD2 valve
- Local Control Module (LCM)

.....

.....

.....

.....

.....

.....

.....

.....

.....

.....

TO ORDER, PLEASE CALL +32 2 351 1800

PR70 - PR70V : SPECIFICATIONS



Stainless Steel Tank
(SST)

■ Tank size

- Capacity 3 to 7.5 liters (stainless steel, Al)
- Capacity 8 liters (polyethylene, PE + Al)
- Capacity 30 to 60 liters (separated + Al)

■ Our options for tanks

- Covers for agitation kits
- Covers for degassing kits
- Covers for drying kits
- Dust covers

■ Machine options

- Control gear
- Fluid recirculation
- Power systems
- Heating piping and tank
- Auto - filling tanks
- Input / Output

SPECIFICATIONS

Metering Pump Effective Area	0.124 - 1.49 in ² (80 - 960 mm ²) per side
Small Air Cylinder Effective Area	7.07 in ² (4560 mm ²)
Large Air Cylinder Effective Area	15.9 in ² (10260 mm ²)
Maximum Stroke Length	1.50 in (38.1 mm)
Minimum Stroke Length	0.23 in (5.8 mm)
Volume per Cycle	0.12 - 4.3 in ³ (2 - 70 cc)
Pump Cycles per 1L [.26 gal]	500 - 14.3
Ratios (fixed)	1:1 to 12:1 depending on cylinders selected
Ratios (variable)	1:1 to 24:1 depending on cylinders selected
Maximum Fluid Working Pressure	3000 psi (207 bar, 20.7 MPa)
Maximum Air Input Pressure	100 psi (7 bar, 0.7 MPa)
Maximum Cycle Rate	30 cpm
Maximum Operating Temperature	70° C (160° F) nylon pistons 50° C (120° F) UHMWPE pistons or PE tanks
Air Inlet Size	1/4 NPT(f)
Pump Fluid Outlet Size	-03, -04, -06, -08 or -12 JIC fittings for 3/16 in (4.8 mm), 1/4 in (6.4 mm), 3/8 in (9.5 mm), 1/2 in (12.7 mm), 3/4 in (19.1 mm) hoses
Wetted Parts	303/304, 17-4 PH, hard chrome, Chromex™, carbide, chemical resistant O-rings, PTFE, nylon, UHMWPE
Weight - PR70	120 lb (55 kg) typical with two 7.5 l tanks 330 lb (150 kg) typical with two 60 l tanks
Weight - PR70v	160 lb (73 kg) typical with two 7.5 l tanks 370 lb (168 kg) typical with two 60 l tanks
Weight - PR70e	100 lb (46 kg) typical without tanks
Electrical Power	100-240V 50/60Hz 1 phase for machine - 80 watts 208-240V 50/60Hz 1 phase for heat - 10 kW max 120 or 240V 50/60Hz 1 phase for on-board agitators
Compressed Air	< 10 scfm typical (varies with cycle time)

INSTRUCTIONS MANUALS

PR70 with Display Module Operation & Maintenance	312393
PR70/PR70v with Advanced Display Module	312759
MD2 Valve Instructions and Parts	312185
PR70/PR70v Repair and Parts	312760
PR70/PR70v Feed System	312394
PR70v Integrated Heat	312761

MD2 DISPENSING VALVE



Manual Dispense Gun Option



Lever-Actuated Dispense Valve

Minimizes maintenance time and costs while maximizing dispense time

Designed with fewer parts and is easy to clean

Streamlines maintenance and service

Complete modular design adapts to different installation needs

No unique tools required

Adjustable Snuff-back Control

Dispenses material only where you need it

Independant Air Cylinder

Improves mean time to repair (MTTR)

Chromex™ Shafts

Extends shaft life to better handle abrasive materials

Grease Isolation Chamber

Ideal for moisture-sensitive materials
Accessible grease fittings for easy maintenance

All-SST Wetted Section

Maximizes material compatibility

Adjustable Inlet Position

Flexibility during system installation
Minimizes dead spaces in fluid path



HFR METERING SYSTEM



SPECIFICATIONS

Dimensions	122 x 150 x 86 cm (48W x 59H x 34D in)
Mix ratio range	Fixed ratio, 1:1 to 16:1, shot to continuous flow
Ratio tolerance range	Up to +1%
Fluid filtration	20 mesh standard
Minimum Flow rates	7.5 cc/s (0.12 gpm)
Maximum Flow rates	316 cc/s (5.0 gpm)
Fluid inlets without feed kits	3/4 npt
Max. mixed fluid working pressure	207 bar, 20,7 MPa (3000 psi)
Min. pump inlet fluid pressure	0.3 bar, 0,03 MPa (50 psig)
Max. ambient temperature	49°C (120°F)
Weight Base machine	287,6 kg (634 lb)
Weight Fully configured	393,7 kg (868 lb)
Wetted parts :	
Pumps (A and B)	Stainless steel, PTFE, UHMWPE, tungsten carbide
Manifold	Aluminum or stainless steel
Applicator	Varies based on applicator chosen
Primary heaters	Aluminum, carbon steel
Fluid viscosity range	Until 30 000 cp

PRESENTATION

The piston rods Chromex and Severe Duty cylinders associated with stainless steel fittings ensure a long service life of the pump without corrosion. Seals piston rods designed for extended life and easy replacement. Preventive maintenance counter to predict maintenance of the unit based on the production schedule. Linear thrust bearings which eliminate side loads to maximize the lifetime and the performance of seals.

With the Graco HFR Metering System, you accurately measure a specific ratio and volume – first time, every time. As the machine dispenses material, it automatically fine-tunes and adjusts to achieve a consistent material flow or pressure. With a +1% ratio accuracy, you reduce scrap and rework with accurate, on-ratio dispensing.

The Graco HFR Metering System is a high-quality meter, mix and dispense system that offers more technology and functionality – at a lower price than traditional custom RIM systems. A low initial investment allows you to participate in the marketplace where it may not have been possible before.

The system's horizontal pumps can be rebuilt at your facility, eliminating costly rebuilds and the need for backup pumps. Less downtime, reduced maintenance costs, and lower parts inventory mean more profits for your company.

HFR : PERFORMANCES

Advanced Display Module

Provides easy setup, monitoring and system diagnostics
 USB drive for data reporting
 Stores 100 shot sizes and five sequences of 20 positions each

IsoGuard Select System

Prevents isocyanate crystallization – less maintenance, more uptime

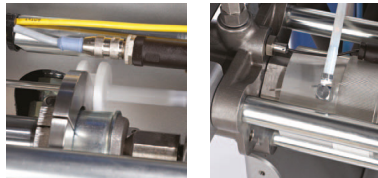

Fully Configurable

Select what you need for your material and application - no more, no less
 Shorter lead time than custom solutions
 Standard wear parts are quickly available

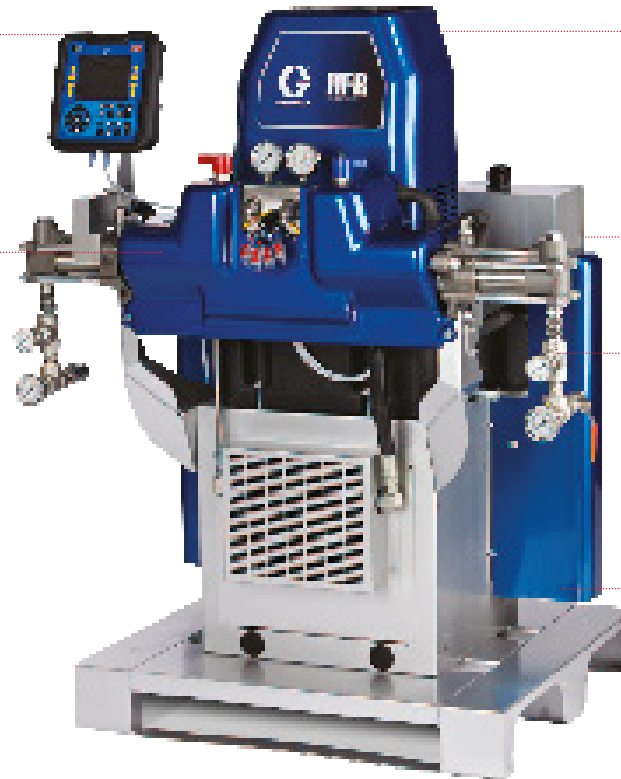

Motor Control Module

In constant communication the Advanced Display and Motor Control Modules make real-time adjustments to deliver a highly precise dispense

Power Distribution Box

Modular assembly replaces complex wiring

Graco Z-Series Horizontal Pumps

Provide precision control to eliminate pressure spikes
 Positive displacement pumps are easy to service with easy-to-replaced cartridge packings, seals and pumps seats

Compact Design

Small footprint saves valuable space in your plant
 122 x 150 x 86 cm (48W x 34D x 59H in)

ADVANTAGES

A modular design gives you the freedom and flexibility to configure the components that are essential for your specific application requirements – no more, no less. Standard configured equipment can be delivered to your door much faster than a custom solution.

And with Graco's established global distribution network, service is there when you need it.

- Provides precision control to eliminate pressure spikes
- Positive displacement pumps are easy to service
- "Real" positive displacement pump
- Elastomeric seals and positive ball checks
- Wide variety of materials – Fillers, high viscosity, abrasive fluids
- Close loop control on pressure and flow

REMARKS

.....

.....

.....

.....

.....

.....

.....

.....

.....

.....

GRACO EP POUR GUN

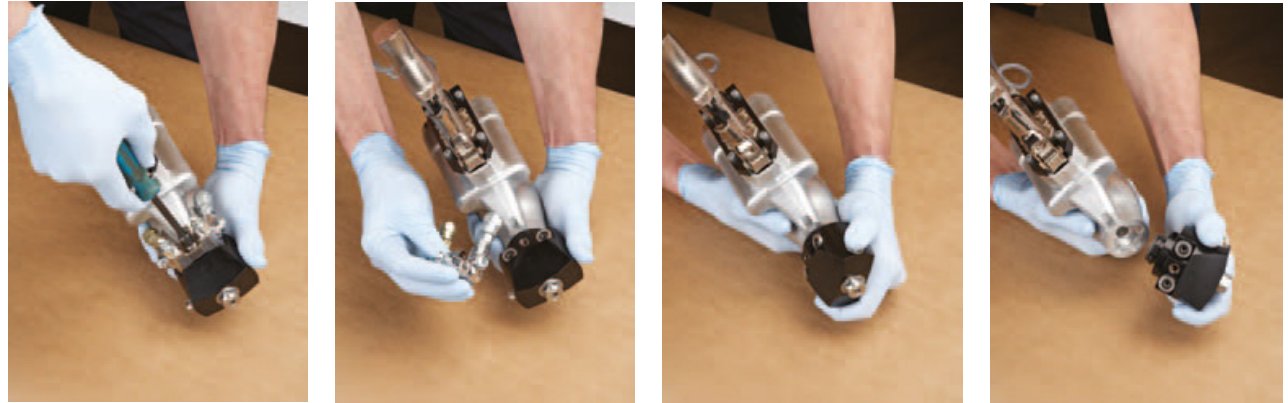

Easy Mixhead Rebuilds

PRESENTATION

The Graco EP Pour Gun is sure to change the way the industry thinks about mixheads. That's because it's engineered to be reliable, light and versatile with features and technology that reduce your cost of ownership in the long run.

The Graco EP Pour Gun is truly an innovative advancement for the polyurethane processing industry. First of all, it's engineered with technology that allows for on-site rebuilds. Which means significantly less downtime and no more expensive backup mixheads. Secondly, it's affordable, with a low initial investment. Best of all, the Graco EP Pour Gun provides accurate on-ratio dispensing and handles a variety of materials.

- Low initial investment
- Updated technology allows for on-site rebuilds
- Reduces downtime
- Eliminates expense of backup mixheads
- Processes both rigid and flexible polyurethanes
- Handles filled materials
- Maintains accurate mix ratio
- Responsive trigger delivers repeatable and accurate shots
- Weighs 6.4 to 7.4 lb (2.9 to 3.4 kg)
- Manual and automated capabilities
- Graco HFR Metering System™

PR70 - HFR : ADVANCED DISPLAY MODULE

MATERIALS

Polyurethane foams

Polyurethane elastomers

Epoxies

Silicones

Polyureas

Soft filled materials

APPLICATIONS

Polyurethane processing

Coating

Potting

Encapsulating

Vacuum infusion

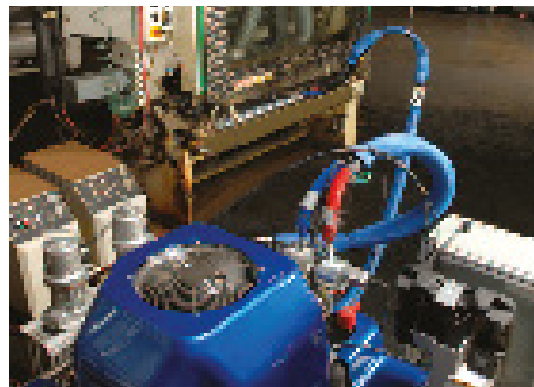

ADVANCED DISPLAY MODULE

The Graco HFR Metering System features intuitive user interfaces based on the Graco Control Architecture,™ a modular system of processing and control components. Products using Graco Control Architecture provide similar interface functionality across your plant and simplify training. Maintenance and service is easier too, thanks to built-in troubleshooting tools and simple, modular part replacement.

Material dispensing reaches a new level of precision due to proprietary algorithms and adaptive technology. The Graco

Metering System uses advanced controls to monitor the system and control the dispensing and material conditioning processes. The system is capable of producing either a constant pressure material output or a constant flow rate material output.

The advanced Display Mode is easy to understand and operate. Because it's easy to use, you spend less time on training and reduce operator error as well.

- Programmable shot sizes and sequencing
- Easy configuration of integrated temperature controls
- Immediate access to error/event history
- Material usage and pump cycle counter
- Simple interface for machine calibration
- Allows you to archive valuable setup parameters

PD44 DISPENSING SYSTEM : HIGH PERFORMANCE VALVE

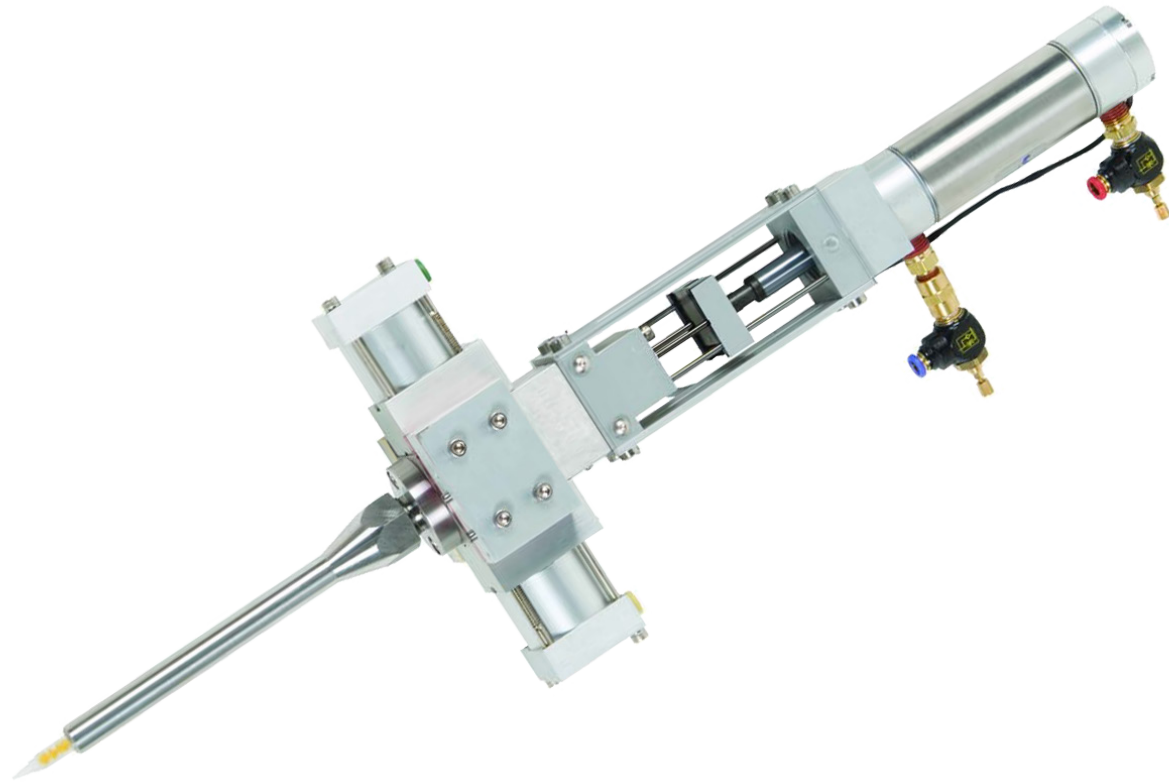

BENEFICES

The PD44 is specifically designed to dispense small amounts of water thin to paste viscosity materials from 0.005cc's to 5cc's. The metering rods are matched with machined seals for improved seal life. There are no material hoses between the rod pump outlets and mixer inlet which eliminates potential ratio or shot size problems (phasing) due to hose expansion and contraction.

Improved low viscosity spool design

Rod positive displacement metering

Precise mix ratio and shot repeatability

Eliminates cleaning and potential hardening of materials in the valve

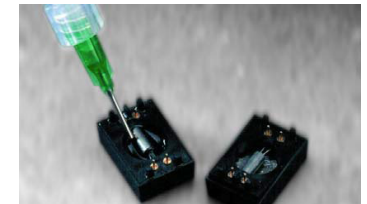
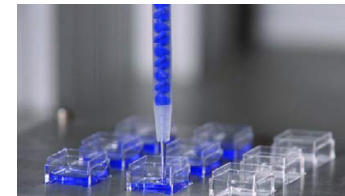

PRESENTATION

The patented PD44 valve features balanced inlet/outlet spool assemblies that do not displace material while shifting from the reload to the dispense position. This allows pressure feeding of the "A" and "B" components up to 1200 psi during reloading while isolating the materials from the mixer inlet. Upon shifting to the dispense position without any material displacement, an accurate volume of "A" and "B" components is injected into the disposable mixer inlet by rod displacement metering technology.

The PD44 provided by Gentec is specifically designed to dispense small amounts of thin water to paste viscosity materials from 0.005cc's to 5cc's. The metering rods are matched with machined seals for improved seal life. There are no material hoses between the rod pump outlets and mixer inlet which eliminates potential ratio or shot size problems (phasing) due to hose expansion and contraction.

REMARKS

.....

.....

.....

.....

.....

.....

.....

.....

PD44: HOW IT WORKS

RELOAD

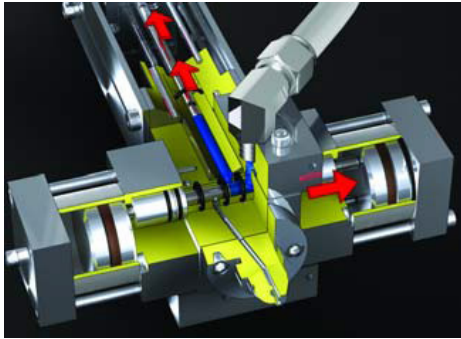

SHIFT

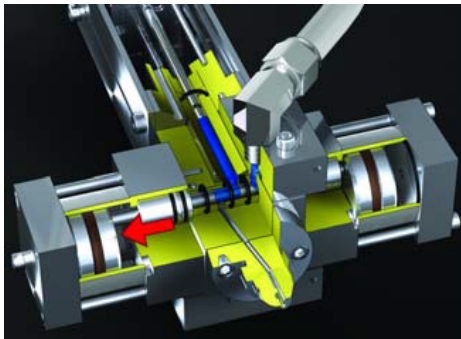

DISPENSE

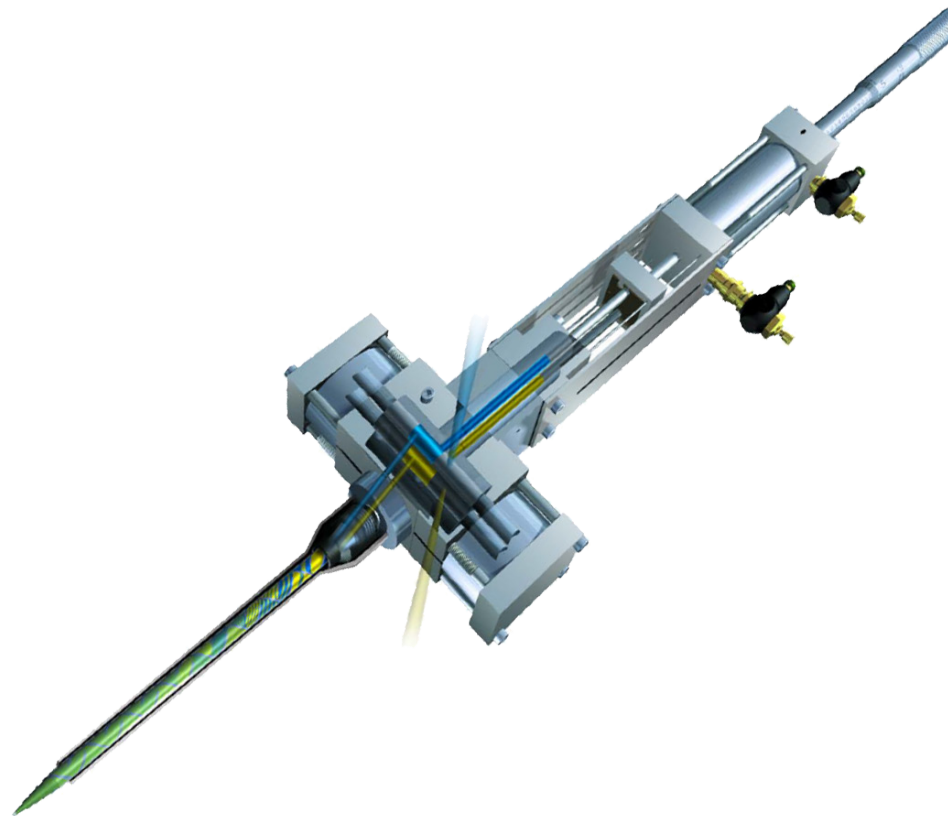
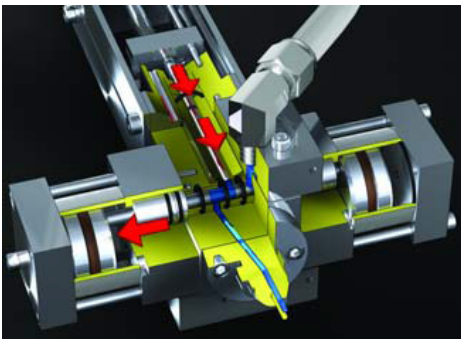

RELOAD

- Spools shift to the right
- Material feed inlets are opened
- Materials are transferred into the metering chambers by a pressurized feed system
- Outlet ports are blocked
- Metering rods are retracted to a precise position determining the volume of each material

SHIFT

- The balanced spool assemblies shift to the dispense position
- Material path to the mixer inlet is opened
- Material feed inlet ports are blocked
- Metering rods remain in the retracted position

DISPENSE

- Metering rods drive down
- A and B materials are simultaneously dispensed from the metering chamber into the disposable mixer
- A and B materials are dispensed at the predetermined ratio
- Upon completion of the dispense stroke, the metering rod and spool assemblies shift back to the reload position

PD44 : VALVE

Shroud and disposable mixer

Material Feed Inlet Block

Balanced Inlet/Outlet Spool/Sleeve Assembly

Machined Seals for longer cycle life

"A" and "B" Precision Metering Rods

Upgraded Sensors

for accurate reloading and dispensing

for accurate and repeatable volume ratio control

for faster response and reliable position control for long term performance

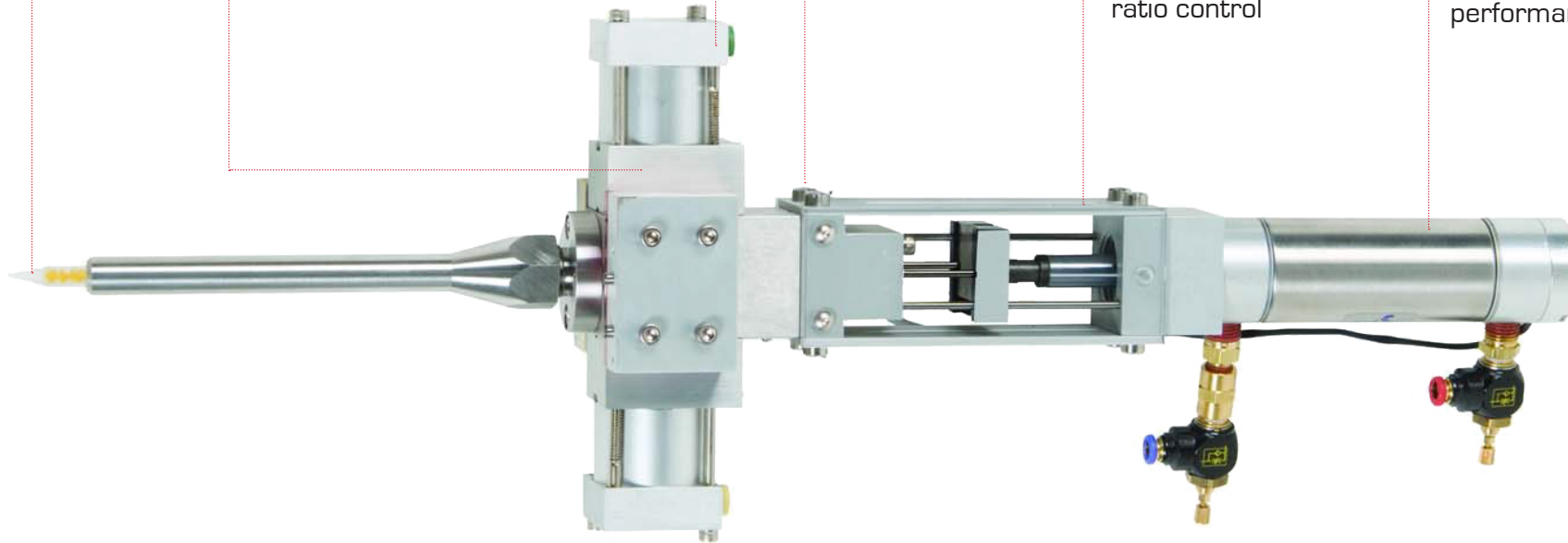

PATENTED PD44 METERING VALVES

Manual control of shot size

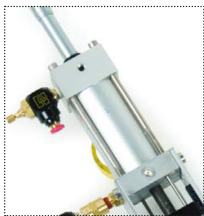

Pneumatically-driven valves have micrometer adjuster to easily set the desired shot size. The micrometer features a locking mechanism to fix the selected shot size

Programmable Shot size control



Linear actuator provides shot size control. Useful feature when a different programmable shot size is required.

Programmable flow and shot size control



Electric drive motor allows programmable shot size and flow rate. This is important when adapting the PD44 valve to X-Y-Z motion tables and to provide precise flow rate control when applying continuous beads of material.

"A" and "B" Metering Rods	<p>A wide selection of standard size metering rods are available depending on the ratio and shot sizes desired. Custom sized metering rods can be machined to accommodate most material ratios. The standard construction of the main body is 303/304 stainless steel. The standard construction of the metering assembly is a nitrided tool steel rod and a nitrided tool steel tube. Optional materials include stainless steel rod with UHMW polyethylene tube and a tungsten rod with UHMW polyethylene tube.</p>
Ratio Range	1:1 to 25:1 by volume depending on the size of the metering rods selected.
Shot Size Capability	0.005 cc's to 5.0 cc's depending on the size of the metering rods selected.
Cycle Rate	<p>Up to 60 cycles per minute with pneumatic drive Max cycle depends on the length of the stroke, size of metering rods, material viscosity, mixer, outlet needle employed and any back pressure or flow limitations created by the product into which material is being dispensed.</p>
Balanced Inlet/Outlet Spool Assemblies	<p>The pneumatically actuated spool assemblies keep the «A» and «B» materials separate in the valve and isolate the material inlets from the outlets to the mixer. The standard construction of the spool assembly is a nitrided tool steel spool and a nitrided tool steel sleeve. Optional materials include stainless steel spool with UHMW polyethylene sleeve and a tungsten spool with UHMW polyethylene sleeve.</p>
Material Feed System	<p>Pressure feed systems including cartridges, tanks and transfer pumps, can be employed to feed «A» and «B» components up to 1200 PSI. The appropriate selection of feed equipment is dependent on material viscosity and processing requirements.</p>
Accessories	Level controls, agitators, follower plates, vacuum degassing, nitrogen blanketing, etc. are readily available
Mixers	<p>Disposable Posimixers are available in sizes from 1/8" (3.175mm) to 3/8" (9.525mm) in diameter and in a various number of elements to provide through blending of most reactive resin systems. Lab tests may be required to determine the specific mixer required for a particular application.</p>
Disposable Needles	<p>From 14 gauge to 30 gauge. A variety of Luer Lock needle sizes are available to adapt to the Posimixer outlets.</p>
Metering Drives	<p>The standard drive is an air cylinder with a precise manual stroke adjustment. Additional drive options include: A linear resistive transducer air cylinder providing electronic shot size control. A stepper or servo ready lead screw actuator for precise shot and flow control</p>
Machine Controls	<p>Free standing table-top control panels are available for air cylinder and motor driven valves. Standard hardware includes: Monochrome touch screen, audio alarm and foot switch. Standard features include: Purge timer, cycle counter and totalizer. Motor driven controls include a NEMA 23 stepper motor featuring shot size and flow rate control</p>
Dimensions	<p>Body - 15" (381mm) H x 4 1/8" (105mm) L x 7 9/16" (192mm) Width Mixer - Add 4" (100mm) to 14 3/4" (375mm) H to the height. Pneumatic Controller - 15" (381mm) W x 12" (305mm) D x 13" (330mm) Height Electric Controller - 20" (508mm) W x 8" (203mm) D x 20" (508mm) Height</p>
Weight	<p>PD44 valve only - 6.35 kg - 6.80 kg (depends on drive). PD44 bench stand and controller - 22.68kg to 34.02kg (depends on options)</p>
Service Requirements	<p>Normal industrial compressed air supply - 0.1 (0.0028 m³/min) to 2.58 CFM (0.07m³/min) at 80psi (5.62 Kg/cm²). Electric - 120/230V, 50/60Hz</p>

CONTROLLER



PNEUMATIC CONTROLLER

- Used for Manual and Programmable dispensing
- Shot Size Control

Sensors in the valve monitor the position of the spool assemblies and metering rods. These sensors interface with the control panel to assure proper valve operation. PD44 systems can help you save material and labour costs for a variety of dispensing applications, whether you are using manual, semi-automated or automated manufacturing processes.

ELECTRIC CONTROLLER

- Used for Programmable dispensing
- Flow and Shot Size

This free-standing table-top controller includes a NEMA 23 stepper motor for precise flow and shot control. Other features include:

- A monochrome touch screen, audio alarm and foot switch
- Seven programmable shot sizes and flow rates
- Customer I/O connections for integration with auxiliary equipment.

SYSTEMS

■ Cartridge Feed Systems

Cartridges of various sizes can be placed in pressurized retainers to allow low to medium viscosity materials to transfer to the PD44 valve

■ Transfer Pumps and Rams

Low to high viscosity materials can be pumped directly from bulk containers using pail and drum rams, transfer pumps and feed hoses as required.

■ Reservoir Tanks

Various sized reservoir tanks can be used to transfer low to medium viscosity materials to the PD44 valve.

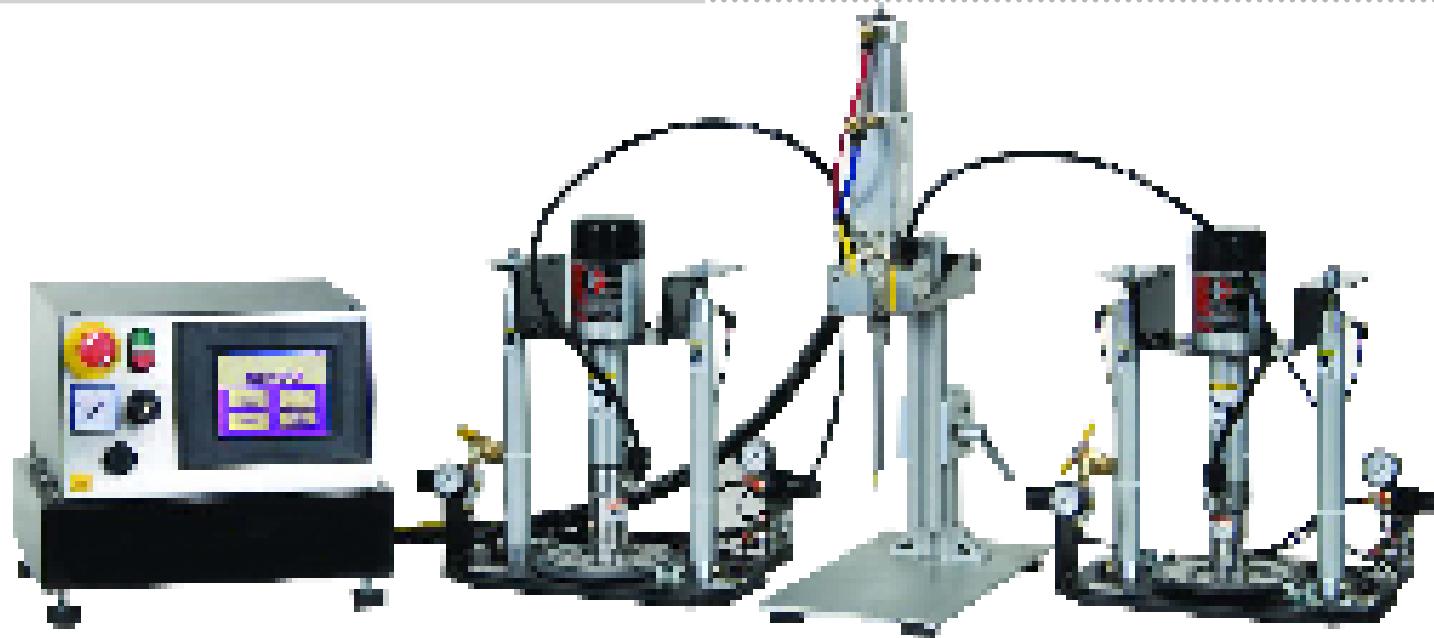

■ Complete System

PD44 with pneumatic controller, manual micrometer shot adjuster and dual one gallon transfer pump feed package.

More informations at power units and devices chapter or at www.gentec-benelux.com



Gentec Benelux

Rue de L'Industrie, 12 B-1400 Nivelles

Phone : +32 2 351 1800

Fax : +32 2 351 1962

Email: webinfo@gentec.be

www.gentec-benelux.com

The fluid dispensing being the cornerstone of numerous production chains, Gentec emphasis on this specific need by proposing a wide range of innovative and efficient dispensing equipments.

French leader on this area, it specialty is to design and implement solutions to put down and dispense every type of fluid in an accurate and repeatable way during the process of assembly. Thanks to it vast field of activity and application, no doubt that Gentec will know how to resolve your most complex problems of deposit and brings you the suited recommendations to optimize your production's capacities.

Persuaded that our expertise must be complete, we also supply you tools in order to prepare your fluid (mixture and degassing) and polymerize your glues (UV sunstroke). Our range of consumables (needles, syringes, static mixers etc are also considered as the best in the market.

So we provide you every type of dispensing equipments to allow you to use efficiently your fluids regardless of the viscosity : glues, greases, lubricants, pastes, solvents, silicones, inks, activators, RTV, paints.

Present in more than 20 countries in the world, performance, quality, service and technology are at the center of all our concerns.